

- \* Przed montażem trzeba przeczytać całą instrukcję.
- \* Za pomocą wykazu części trzeba sprawdzić, czy dostarczono wszystkiego jego części.
- \* Podczas montażu trzeba stosować odpowiednie okulary ochronne albo inne środki bezpieczeństwa.

## Przed montażem

Przed instalacją trzeba się dokładnie zapoznać z niniejszymi wskazówkami. Podczas instalacji trzeba przestrzegać lokalne przepisy bezpieczeństwa i normy przemysłowe. Polecenia mogą między innymi dotyczyć:

- kasku ochronnego, ochrony oczu i odzieży ochronnej
- szelek bezpieczeństwa dla pracowników pracujących na wysokości
- odpowiedniej drabiny, klatki oraz ich bezpiecznego stosowania

Przed instalacją trzeba skontrolować wszystkie elementy i części. Wszystkie części oznakowane są numerem, podczas kontroli trzeba numery porównać z dostarczonym wykazem części.

Dla instalacji trzeba wybrać dzień bez wiatru albo z umiarkowanym wiatrem. W warunkach silnego wiatru jest montaż trudny. Konstrukcji nie należy jakkolwiek poprawiać. Podczas instalacji nie należy na ramę zawieszać jakichkolwiek obciążników ani części. Nie ponosimy odpowiedzialności za szkody albo wypadki powstałe w wyniku niepoprawnej instalacji, niepożądanych popraw albo nieodpowiedniej pogody. Obiekt nie jest przeznaczony do celów mieszkalnych.

Na ramę w miejscach styku ramy i osłony poleca się przykleić albo dodać pianę/gumę. W ten sposób można przedłużyć okres trwałości osłony.

Przed zmontowaniem trzeba najpierw przeczytać wykaz części i obliczyć pozycje w celu sprawdzenia kompletności potrzebnych elementów.

# Główna specyfikacja

Ogólne wymiary po montażu (cm): D 130 \* Š 192 \* V 195 (cm)

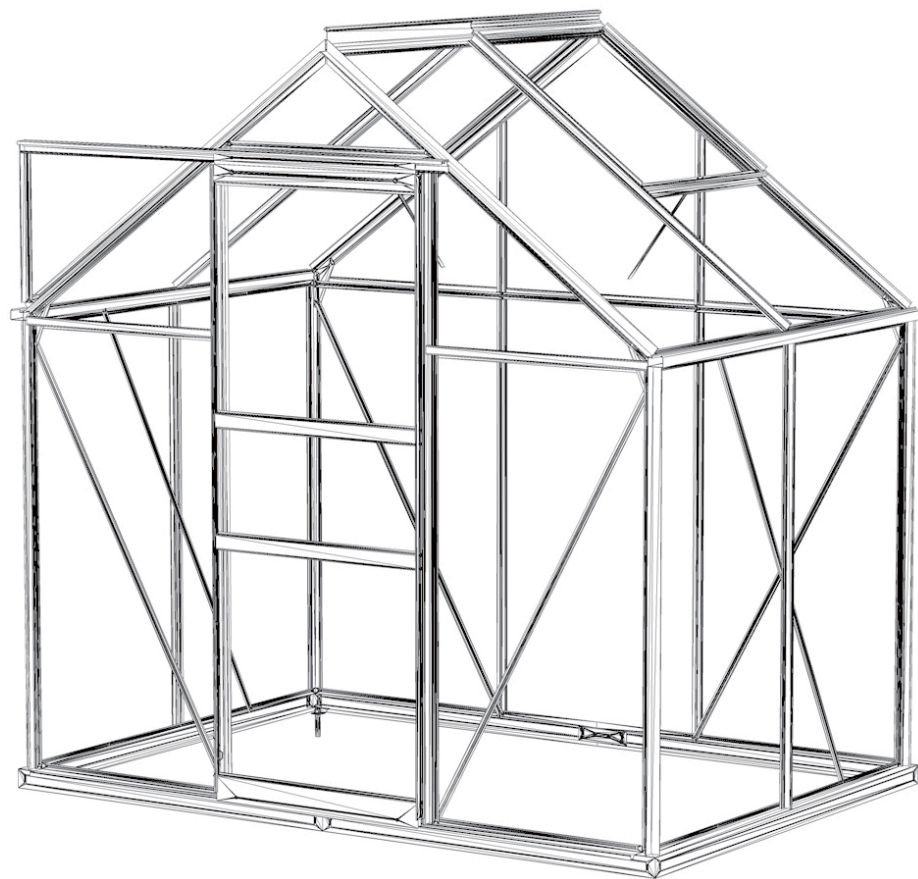

## Poleczone narzędzia

Środki ochronne:

1. Kask ochronny

2. Rękawice

3. Okulary ochronne



Przyrządy pomiarowe oraz urządzenia do instalacji:

1. Przymiar taśmowy

2. Kątownik

3. Drabina rozkładana

4. Klucz C10

5. Wkrętak krzyżowy

6. Flamaster

7. Młotek drewniany

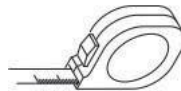























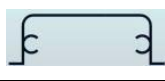













MODEL - MODEL CODE - KOD

LENGTH - DŁUGOŚĆ QTY - ILOŚĆ

## CZĘŚCI ALUMINIOWE

MODEL	CODE	LENGTH (mm)	QTY	MODEL	CODE	LENGTH (mm)	QTY	MODEL	CODE	LENGTH (mm)	QTY	MODEL	CODE	LENGTH (mm)	QTY
	C1301A	1551	1		C501	1150	4		C101A	1606	1		C2201	621	2
	C1301B	1551	1		C201	1150	2		C101B	1606	1		C2202	610	3
	C1801	590	1		C2503	1286.2	2		C203A	1622	1				
	C701	600	1		C2001	1310	2		C203B	1622	1				
	C1101	600	2		C2004	616	2		C1902	628	1				
	C2301	600	1		C2005	635	1		C202	1137	2				
	C2401	607	1		C2103	1234.2	1		C1001	405.5	1				
	C2601	602	1		C503A	1157	1		C401	606	1				
	C2701	600	2		C503B	1157	1		C601	1275	1				
	C801	971.3	1		C503C	1157	1		C2002	1253	4				
	C802	815.9	1		C503D	1157	1		C2003	610	2				









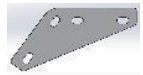

## WYKAZ INNYCH CZĘŚCI

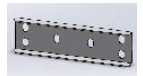
MODEL - MODEL

CODE - KOD



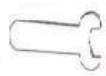









LENGTH - DŁUGOŚĆ

QTY - ILOŚĆ

MODEL	CODE	LENGTH (mm)	QTY	MODEL	CODE	LENGTH (mm)	QTY
	CBJ01	948.8	1		CBJ07	138*69	4
	CBJ03	948.8	1		CBJ09	150*44	1
	CBJ05	948.8	1		CBJ10	30*40	4
	CBJ06	948.8	1		CBJ11	100*44	1
	BJ02	1299.2	2				2
	CBJ14	50*30	4				

MODEL	CODE	LENGTH (mm)	QTY
	C1	28	1
	C2		4
	C4		120
	D1	M6X9*3.5	122
	C5		1
	C3		2
	D2	M6X16	2
	D3	M6X40	2
	D4	M4X10	5
	D5	ST4. 2X9.5	10
	D6	ST4. 8X19	18
	D7	M6-GB41	124
	D8	M10*100	4

## WYKAZ PŁYT

MODEL	CODE	LENGTH (mm)	QTY	MODEL	CODE	LENGTH (mm)	QTY
	K001	562*598	2		A001	1148*617	4
	K002	261*598	1		A003	1150*617	3
	M001	628*604	1		A002	534*617	2
	E003	1146*621	2		D003	1146*610	3
	E002	454*621	2		D001	470*610	2
	E001	240*650	1		D002	698*610	1

MODEL - MODEL

CODE - KOD

LENGTH - DŁUGOŚĆ

QTY - ILOŚĆ

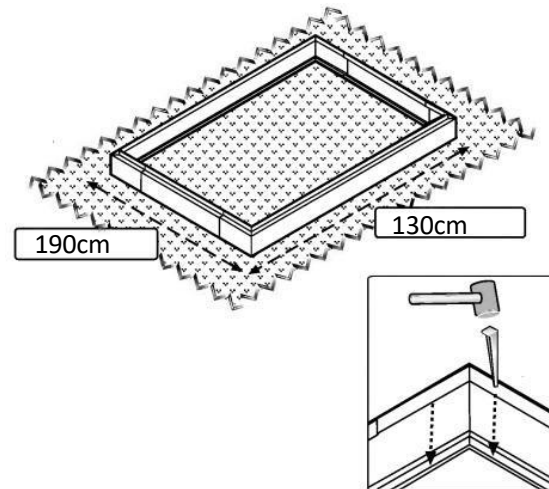
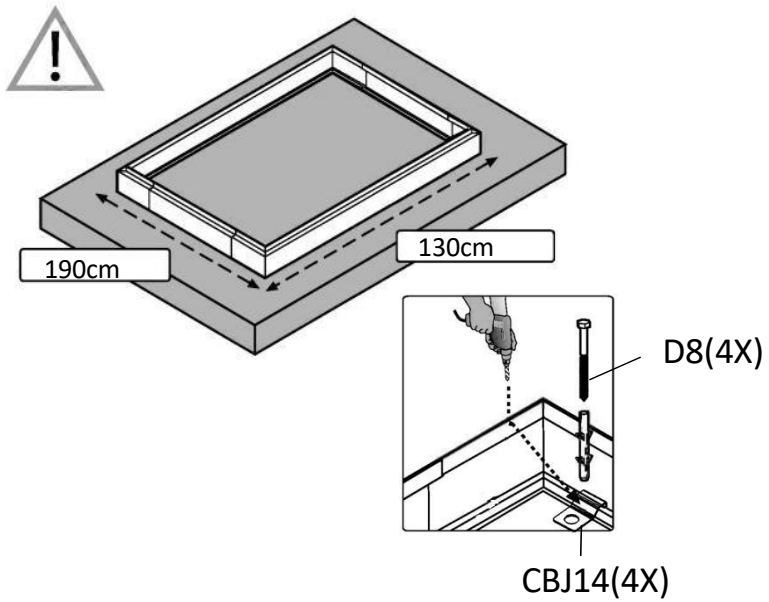
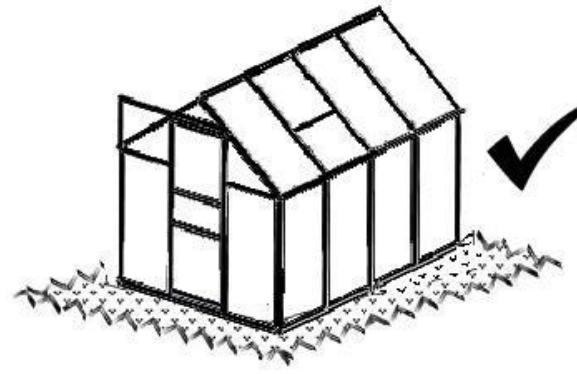
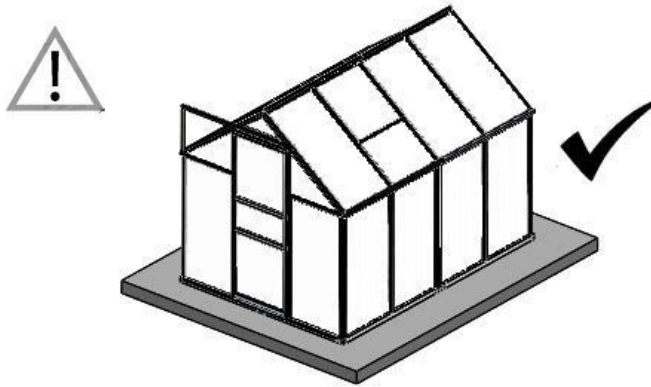

MODEL - MODEL

CODE - KOD

LENGTH - DŁUGOŚĆ

QTY - ILOŚĆ

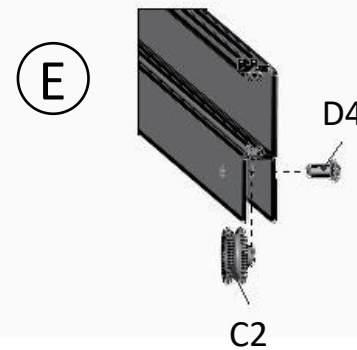
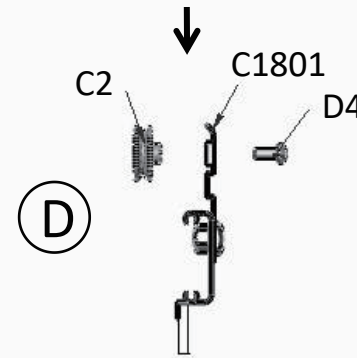
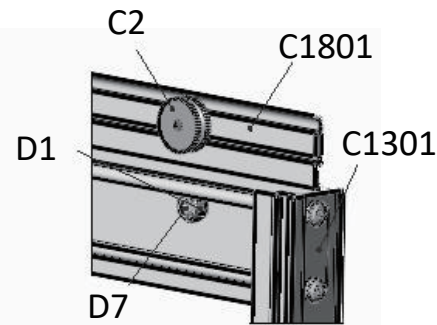
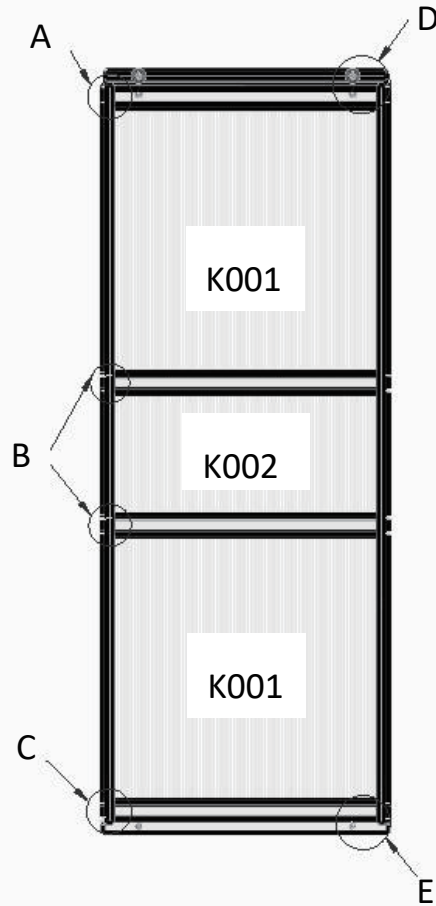
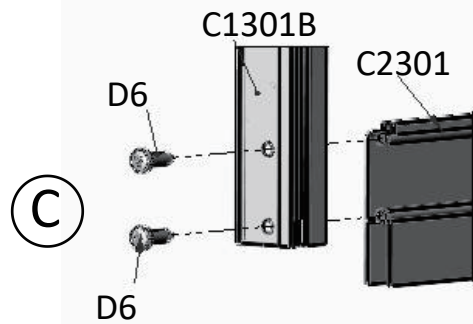
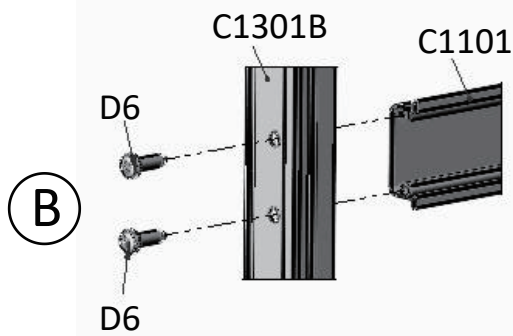
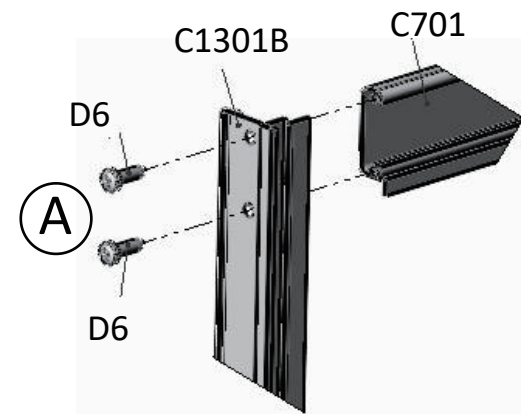

MODEL	CODE	LENGTH(mm)	QTY
	C1301A	1551	1
	C1301B	1551	1
	C1801	590	1
	C701	600	1
	C1101	600	2
	C2301	600	1
	C2		4
	D6	ST4. 8X19	16
	D4	M4X10	4
	K001	562*598	2
	K002	261*598	1
	C4		10
	D1	M6X9*3.5	2
	D7	M6-GB41	2

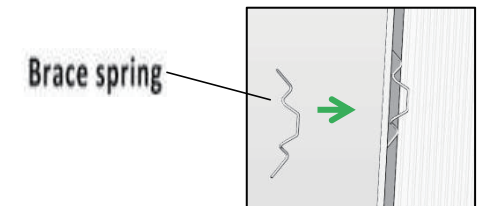

Brace spring - sprężyna usztywniająca

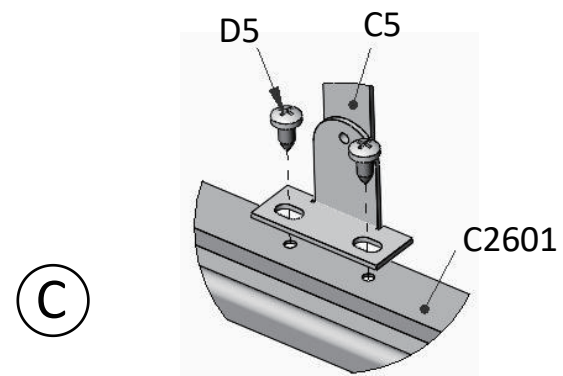
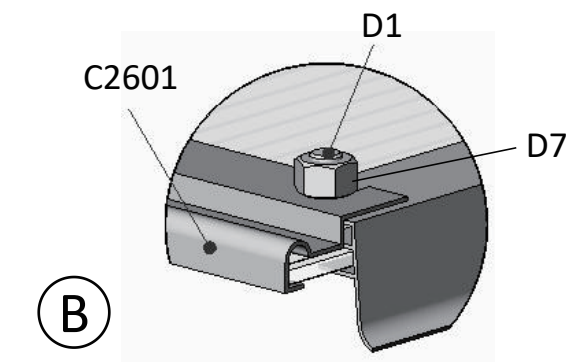
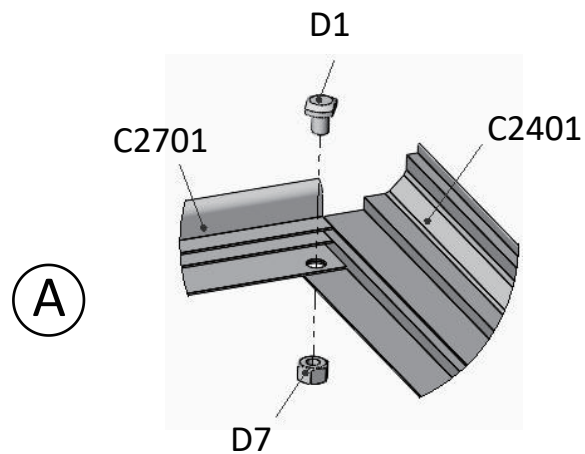
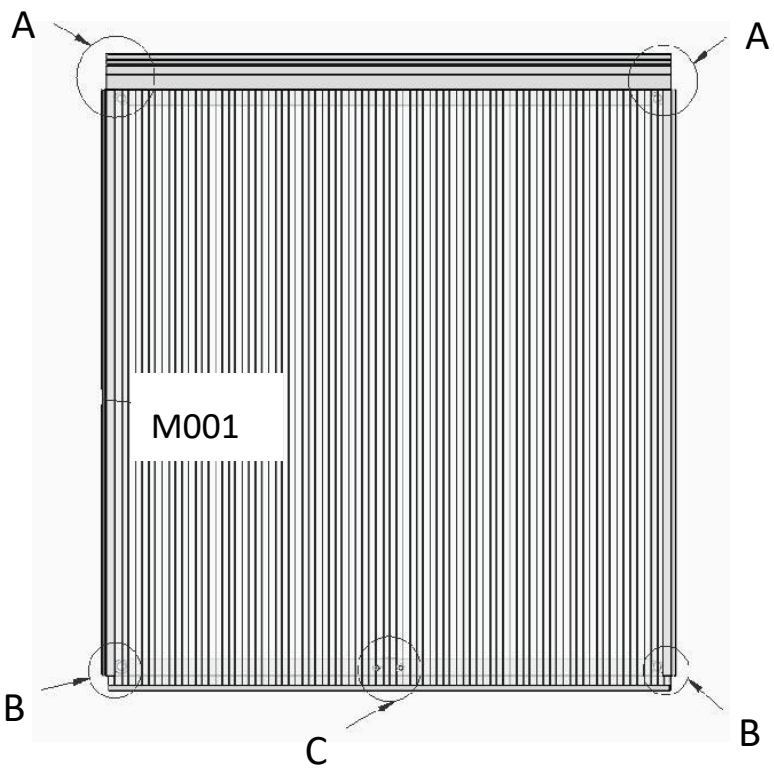

MODEL	CODE	LENGTH(mm)	QTY
	C2401	607	1
	C2601	602	1
	C2701	600	2
	C5	332	1
	D5	ST4. 2X9. 5	2
	M001	628*604	1
	D1	M6X9*3. 5	4
	D7	M6-GB41	4

MODEL - MODEL CODE - KOD

LENGTH - DŁUGOŚĆ QTY - ILOŚĆ



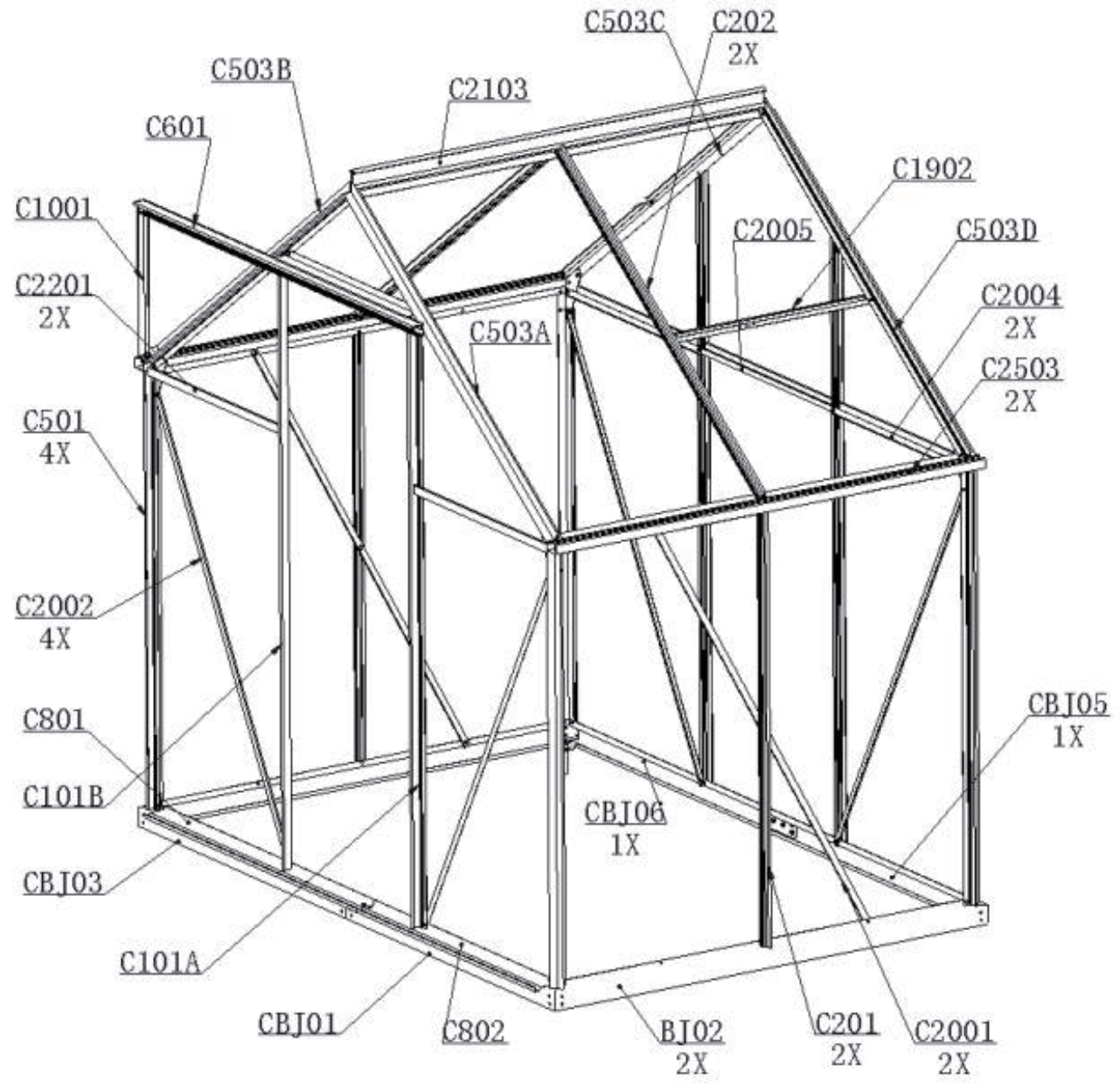



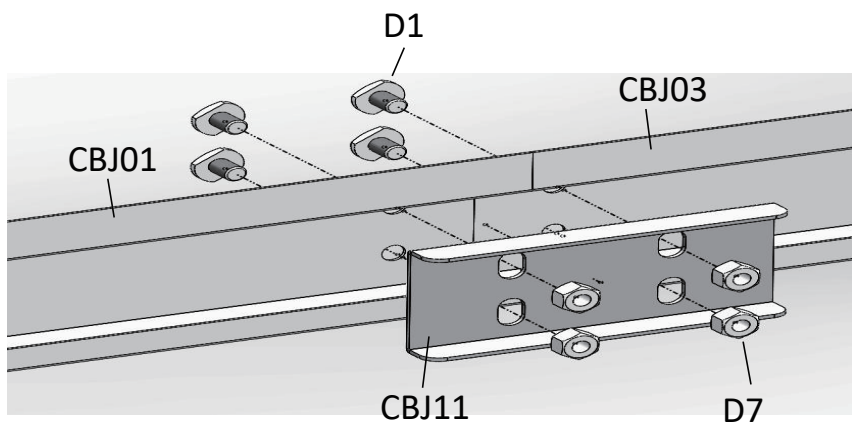

(B1)

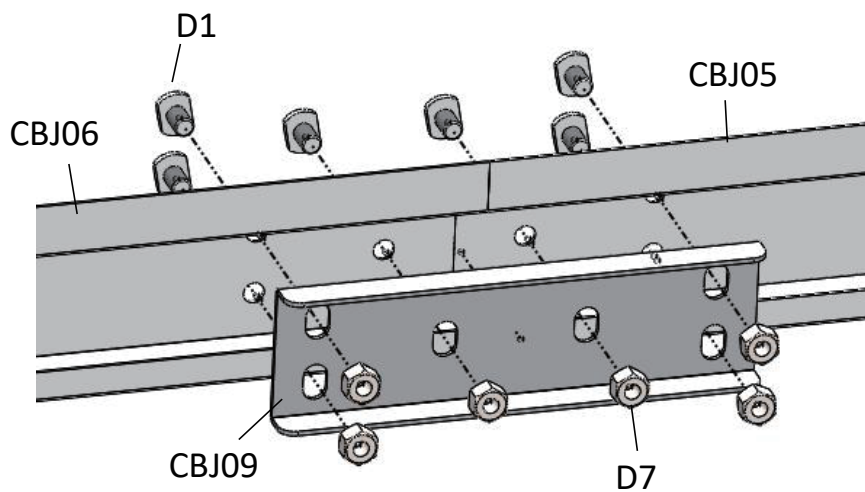

(B2)

MODEL	CODE	LENGTH(mm)	QTY
	CBJ01	948.8	1
	CBJ03	948.8	1
	CBJ05	948.8	1
	CBJ06	948.8	1
	BJ02	1299.2	2
	CBJ09	150*44	1
	CBJ11	100*44	1
	D1	M6X9*3.5	10
	D7	M6-GB41	10



MODEL - MODEL

CODE - KOD

LENGTH - DŁUGOŚĆ

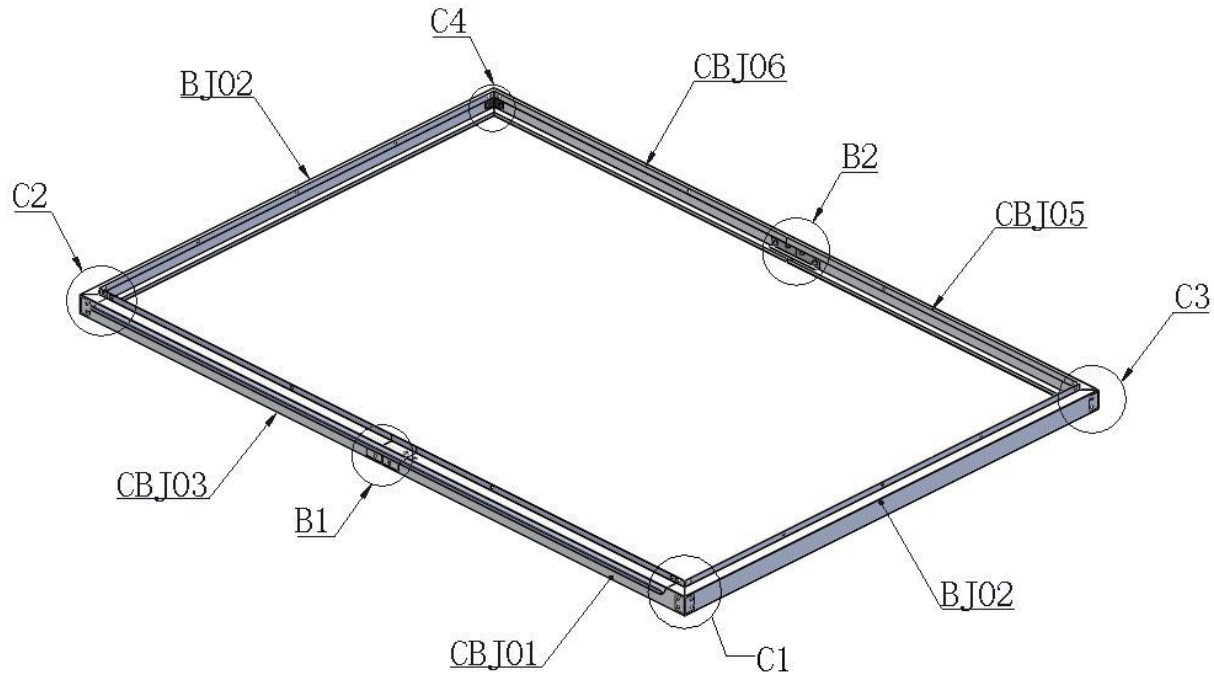
QTY - ILOŚĆ



MODEL	CODE	LENGTH(mm)	QTY
	CBJ10	30*40	4
	D1	M6X9*3.5	16
	D7	M6-GB41	16

MODEL - MODEL                      CODE - KOD

LENGTH - DŁUGOŚĆ                QTY - ILOŚĆ

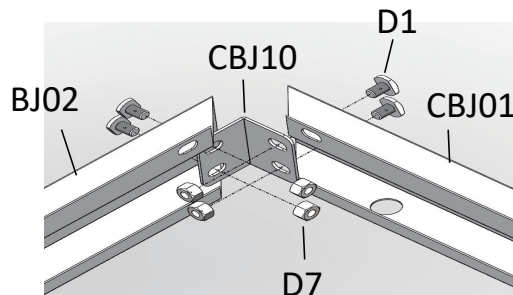

(C1)

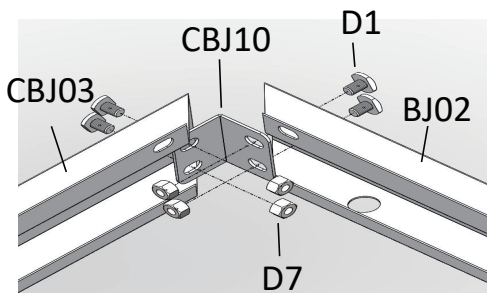

(C2)

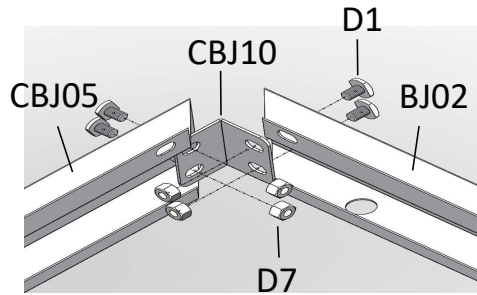

(C3)

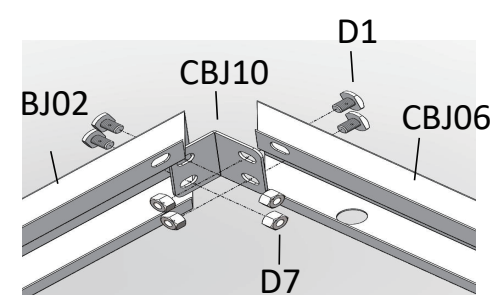

(C4)

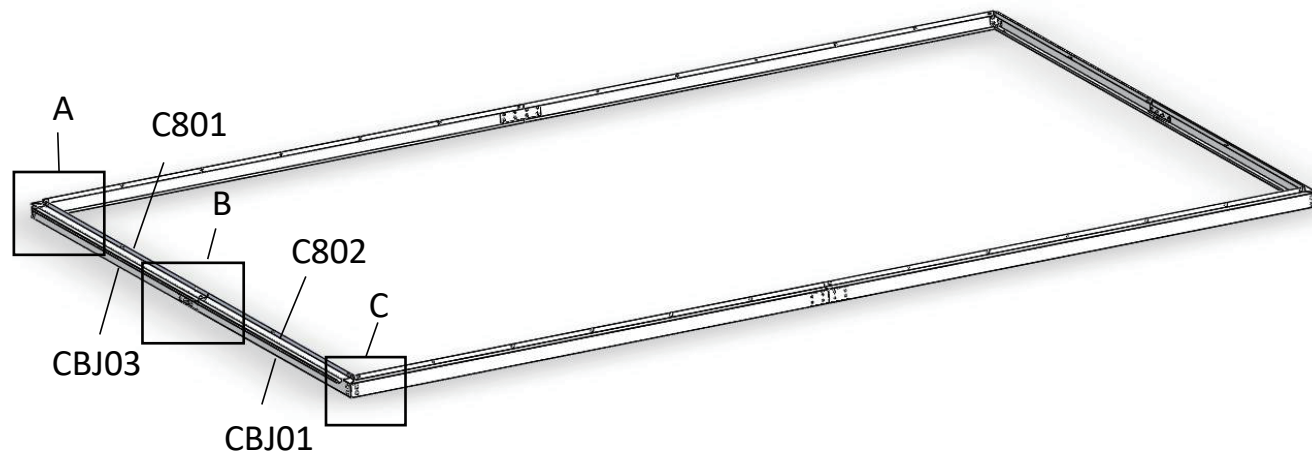



MODEL	CODE	LENGTH(mm)	QTY
	C801	971.3	1
	C802	815.9	1
	D1	M6X9*3.5	4
	D7	M6-GB41	4

MODEL - MODEL      CODE - KOD

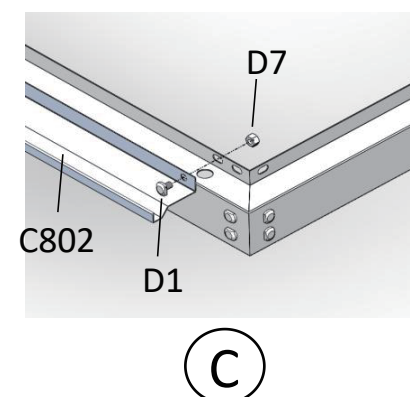
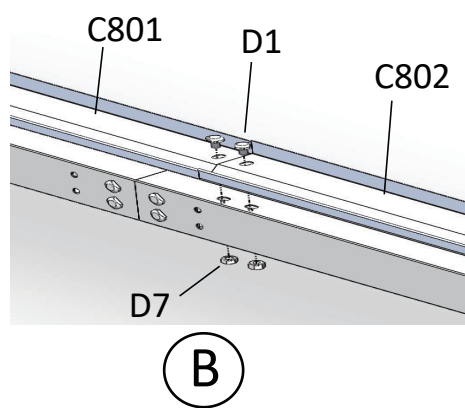
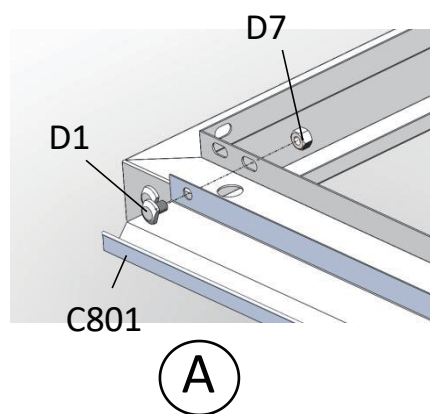
LENGTH - DŁUGOŚĆ      QTY - ILOŚĆ

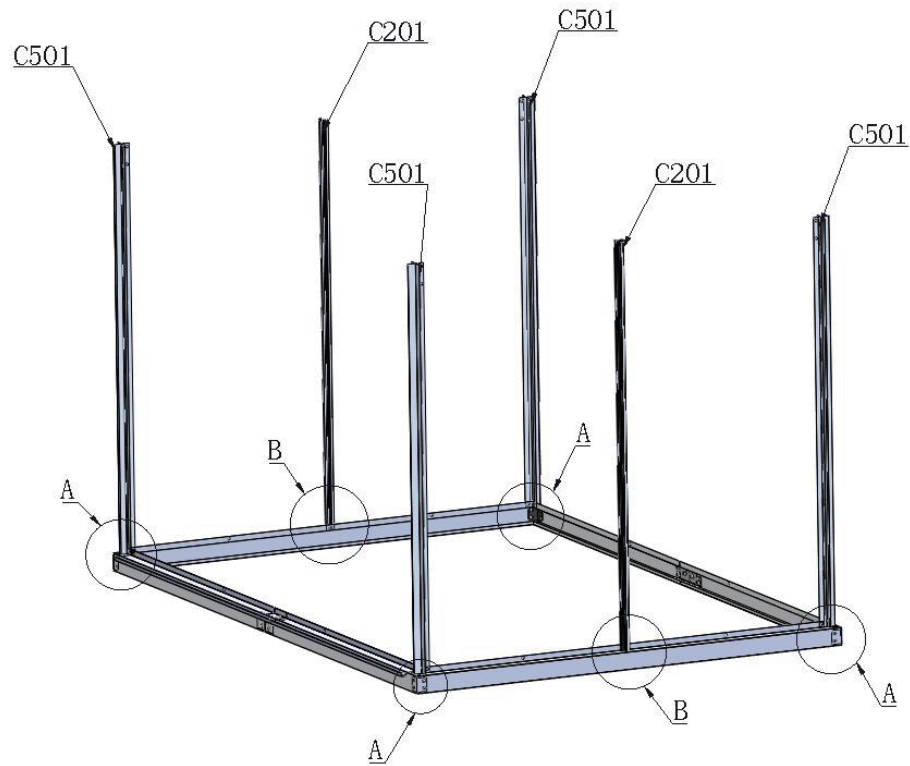





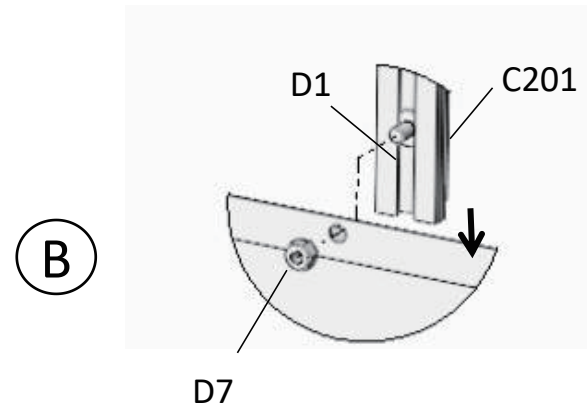
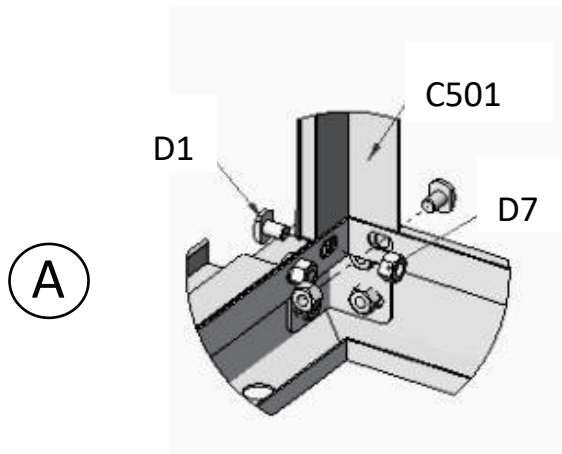

MODEL	CODE	LENGTH(mm)	QTY
	C501	1150	4
	C201	1150	2
	D1	M6X9*3.5	10
	D7	M6-GB41	10

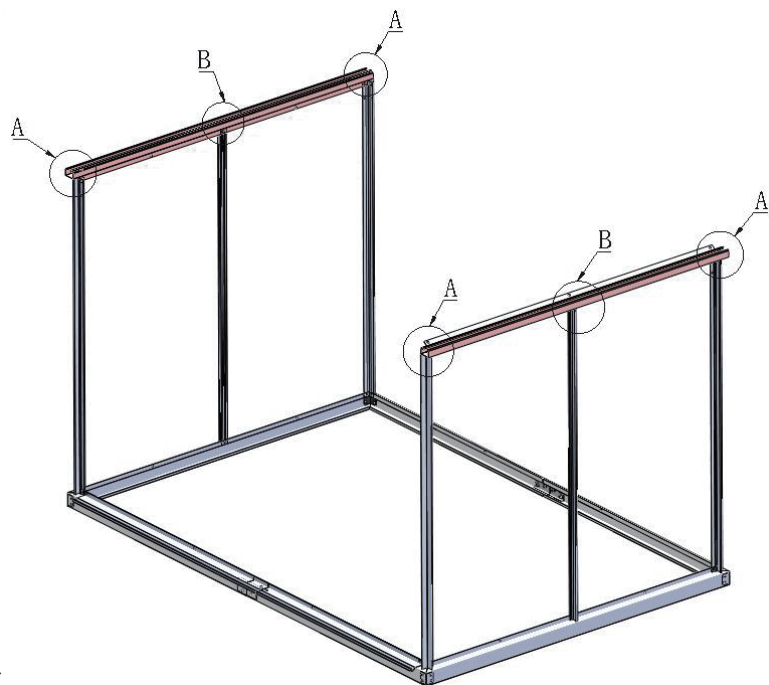
MODEL - MODEL                      CODE - KOD  
 LENGTH - DŁUGOŚĆ                QTY - ILOŚĆ





MODEL	CODE	LENGTH(mm)	QTY
	D7	M6-GB41	6
	D1	M6X9*3.5	8
	C2503	1286.2	2

MODEL - MODEL                      CODE - KOD

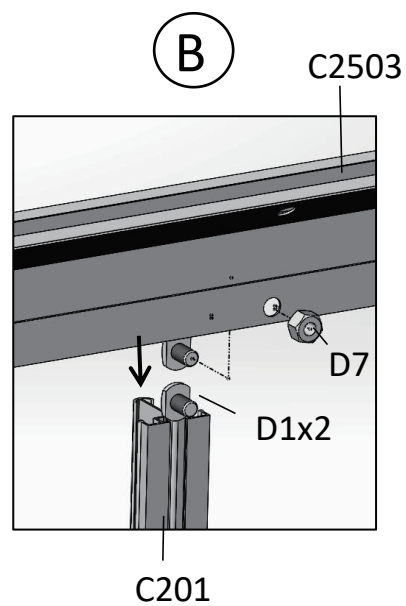
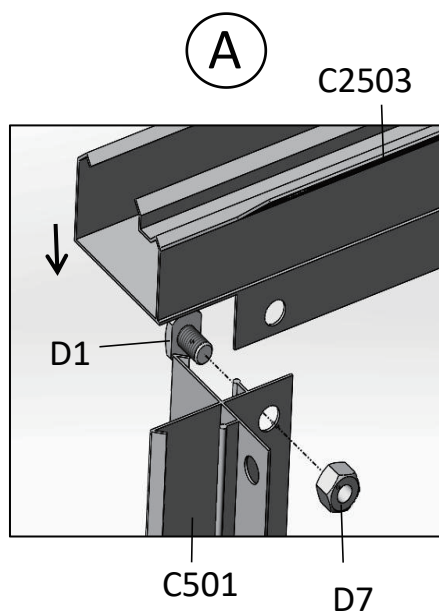

LENGTH - DŁUGOŚĆ                QTY - ILOŚĆ

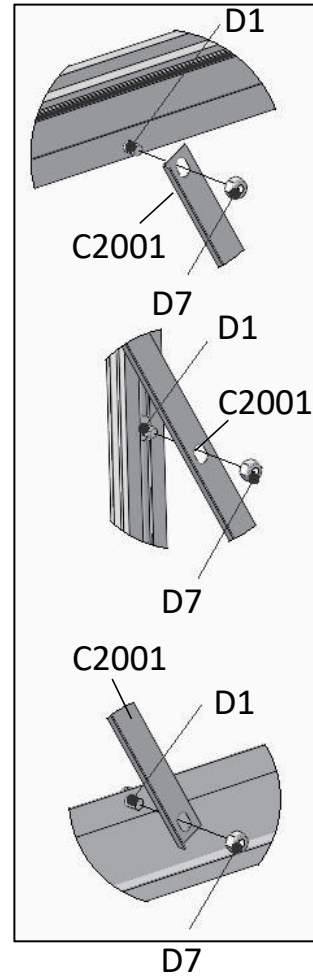
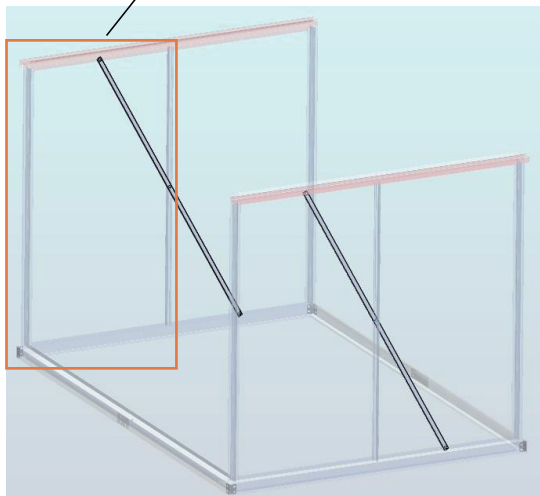
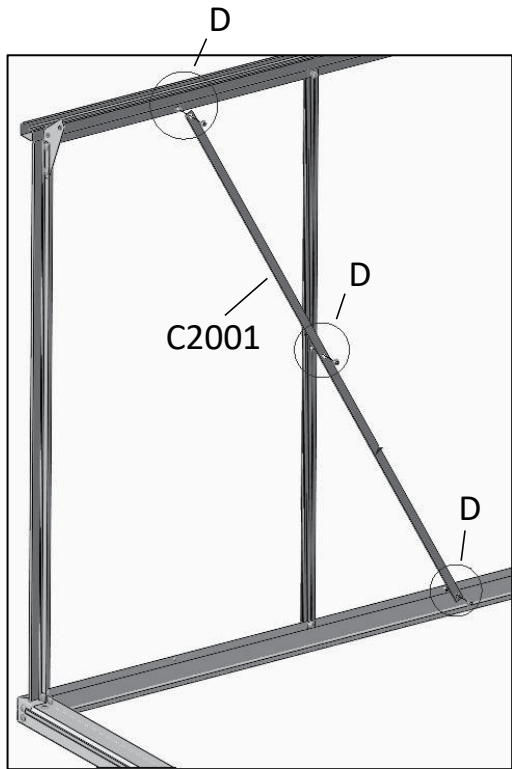

f



(D)

MODEL	CODE	LENGTH(mm)	QTY
	C2001	1310	2
	D1	M6X9*3.5	4
	D7	M6-GB41	6

MODEL - MODEL                      CODE - KOD  
 LENGTH - DŁUGOŚĆ                QTY - ILOŚĆ



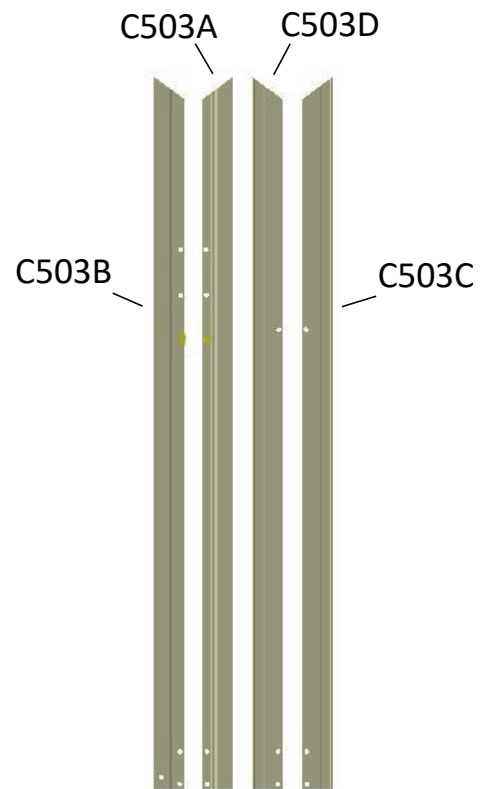
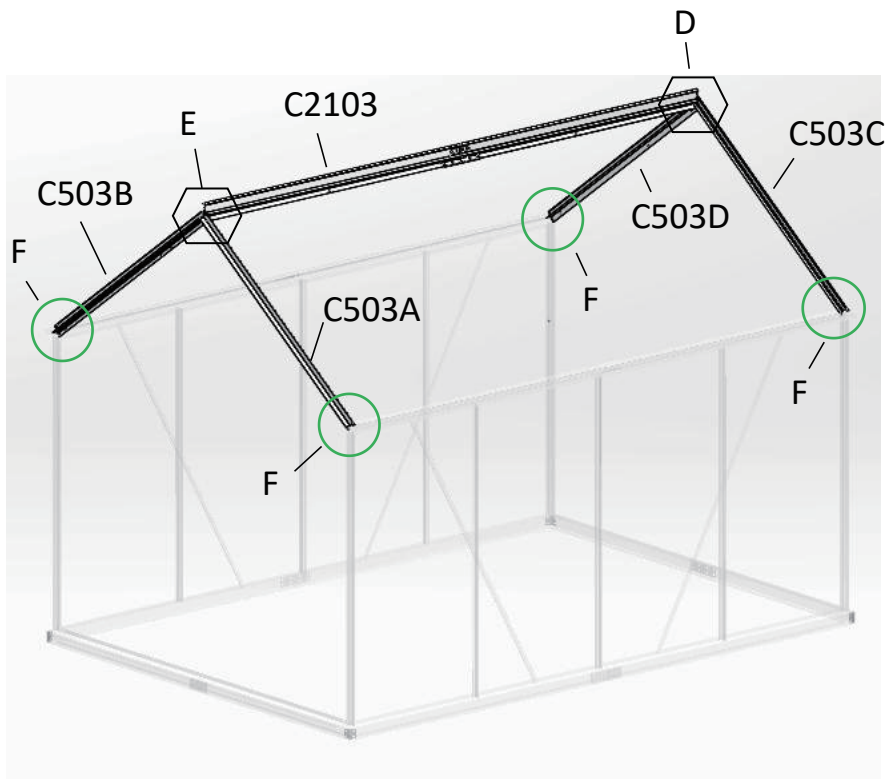

MODEL	CODE	LENGTH(mm)	QTY
	C503A	1157	1
	C503B	1157	1
	C503C	1157	1
	C503D	1157	1
	C2103	1234.2	1
	CBJ07	138*69	4
	D1	M6X9*3.5	20
	D7	M6-GB41	20

MODEL - MODEL CODE - KOD

LENGTH - DŁUGOŚĆ QTY - ILOŚĆ

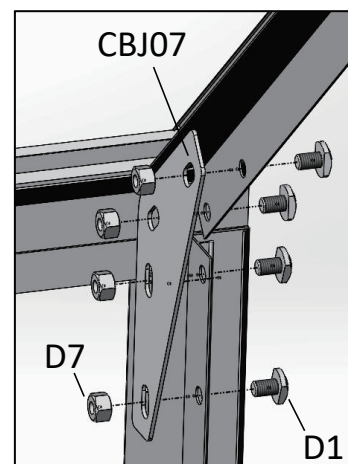
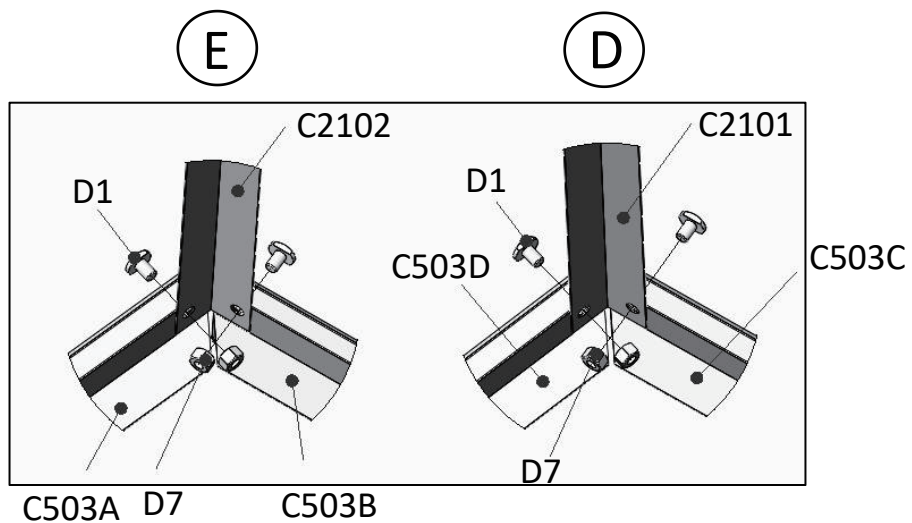

F



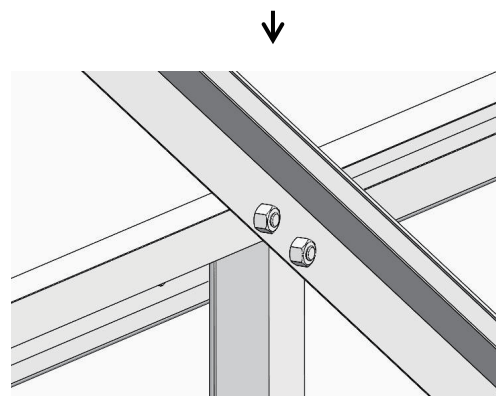
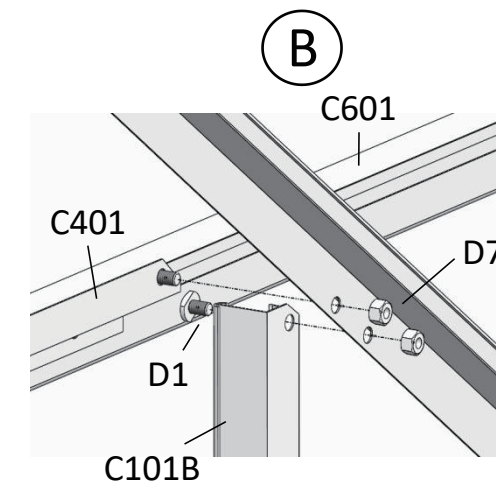
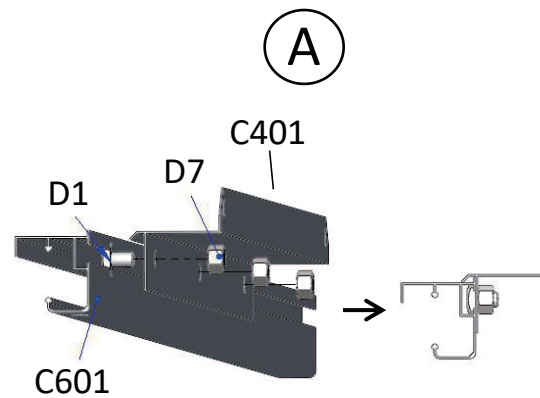
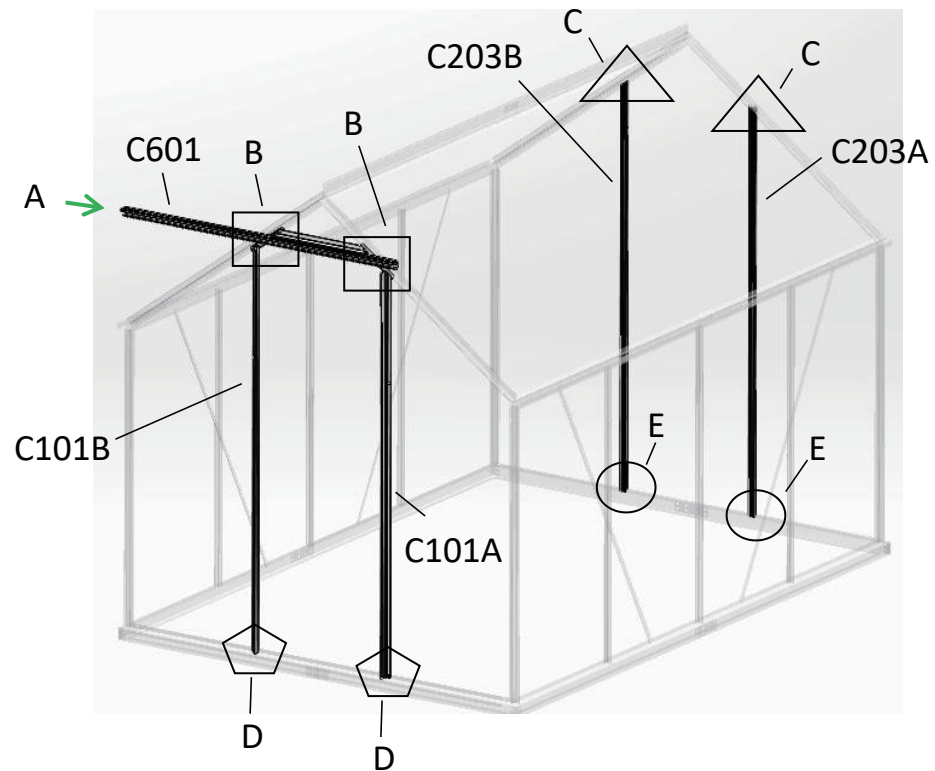

MODEL	CODE	LENGTH(mm)	QTY
	C601	1275	1
	C101A	1606	1
	C101B	1606	1
	C401	606	1
	C203A	1622	1
	C203B	1622	1
	D1	M6X9*3.5	15
	D7	M6-GB41	13

MODEL - MODEL CODE - KOD

LENGTH - DŁUGOŚĆ QTY - ILOŚĆ

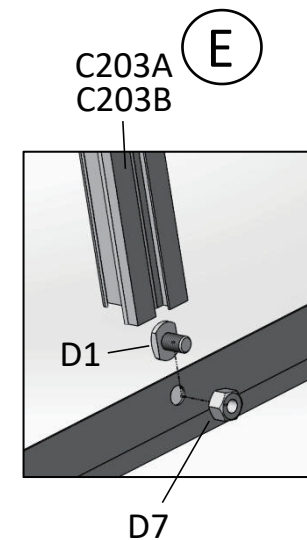
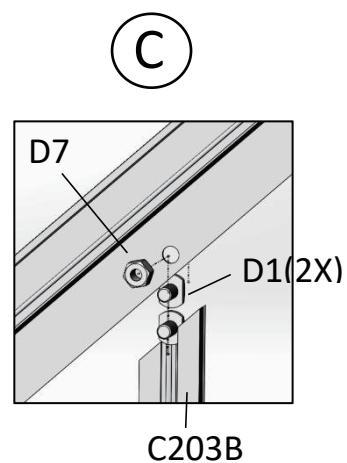
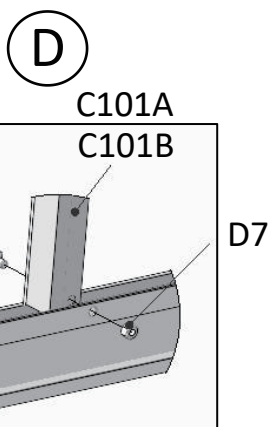

MODEL - MODEL

CODE - KOD

LENGTH - DŁUGOŚĆ

QTY - ILOŚĆ

MODEL	CODE	LENGTH(mm)	QTY
	C2002	1253	4
	C2003	610	2
	C2004	616	2
	C2005	635	1
	D1	M6X9*3.5	2
	D7	M6-GB41	4

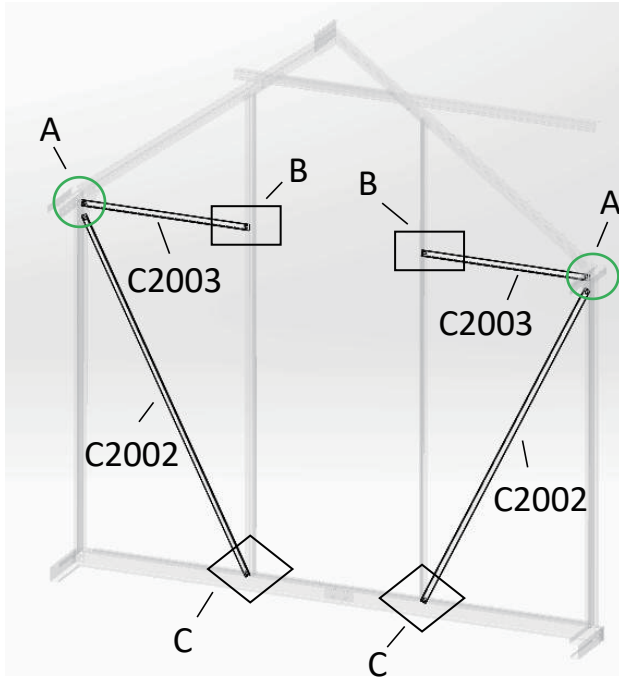

A

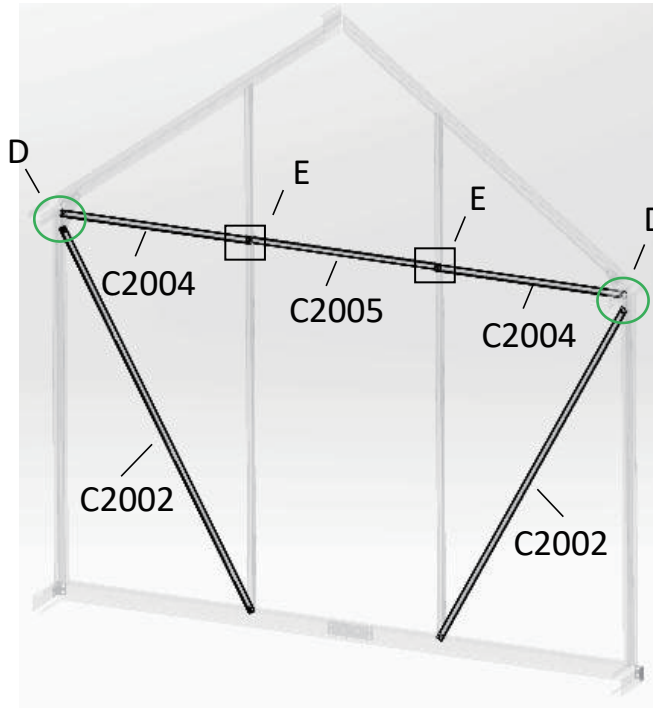

B

C

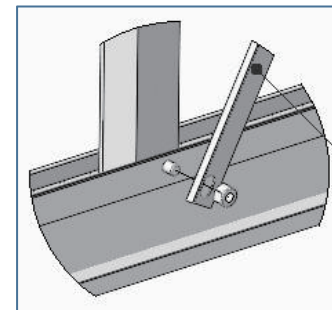
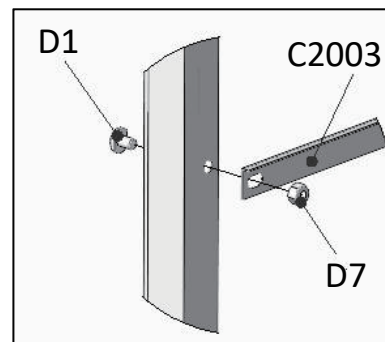
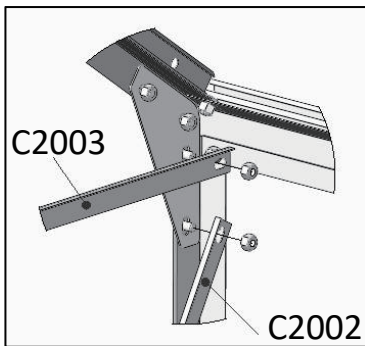

C2002

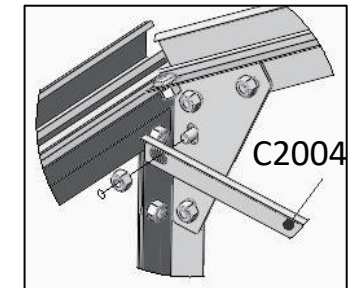

C2004

E

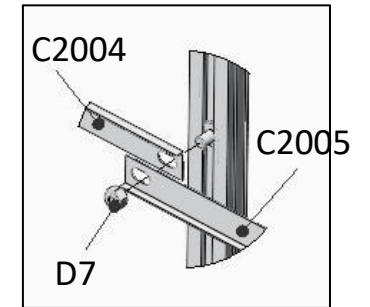

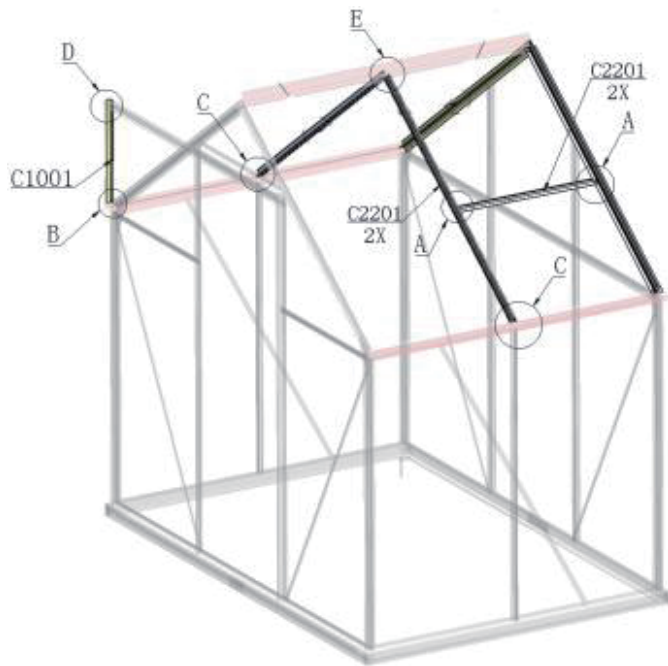

(A)

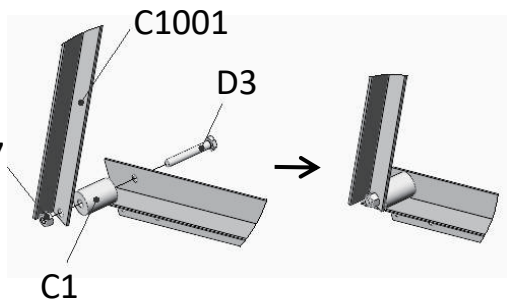
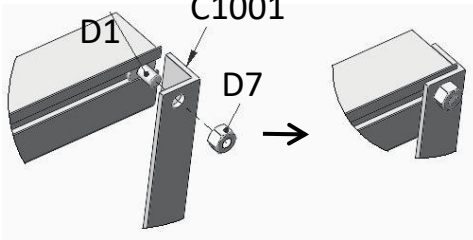
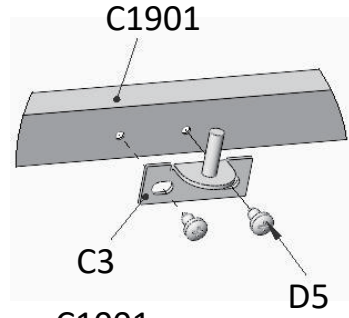
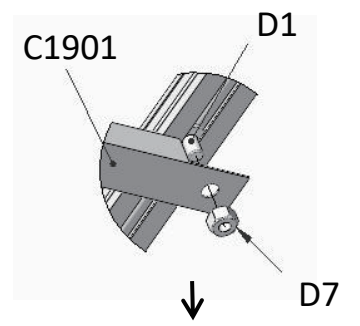

(E)

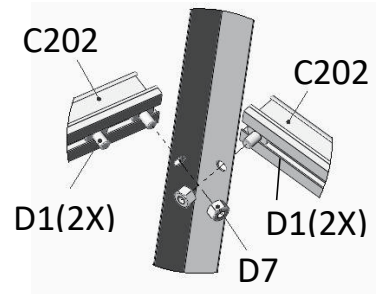

Pierwsza śruba montażowa  
F: D1 (2x)



MODEL	CODE	LENGTH(mm)	QTY
	C1902	628	1
	C202	1137	2
	C1001	405.5	1
	C3		2
	C1	28	1
	D3	M6X40	1
	D5	ST4. 2X9.5	4
	D1	M6X9*3.5	9
	D7	M6-GB41	10

MODEL - MODEL                      CODE - KOD  
LENGTH - DŁUGOŚĆ                  QTY - ILOŚĆ

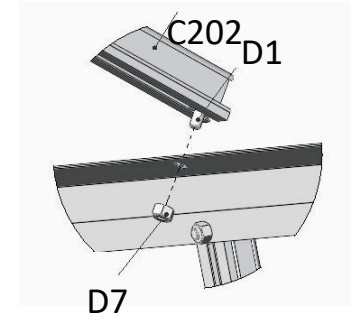
(C)

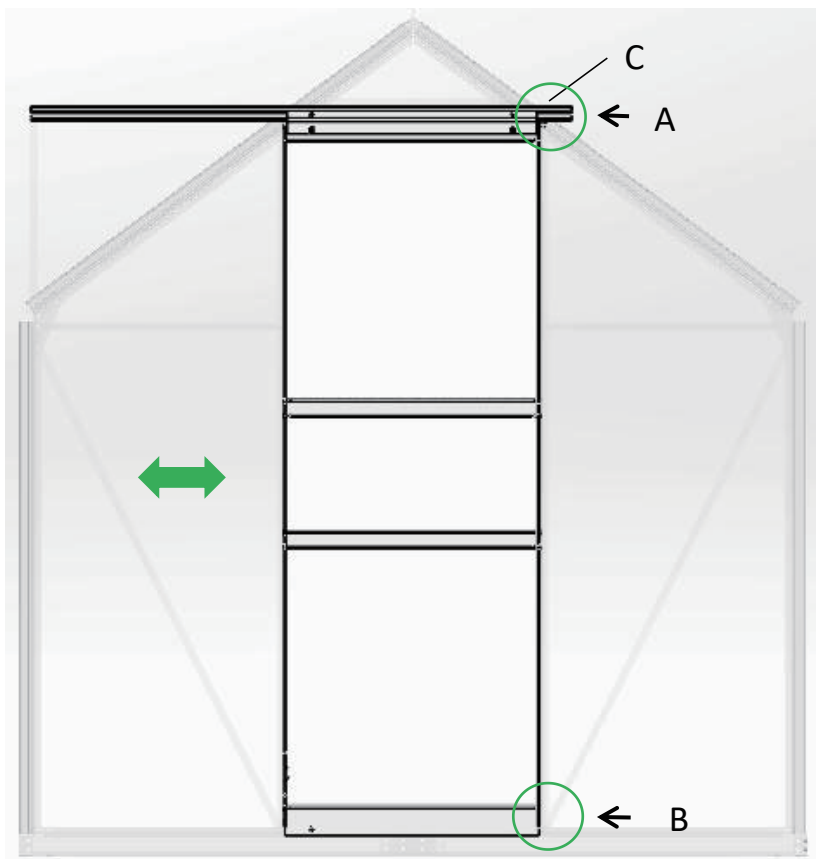



MODEL	CODE	LENGTH(mm)	QTY
	D2	M6X16	1
	D7	M6-GB41	1

MODEL - MODEL

CODE - KOD

LENGTH - DŁUGOŚĆ

QTY - ILOŚĆ

A

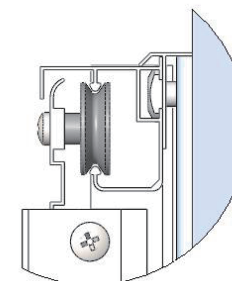

B

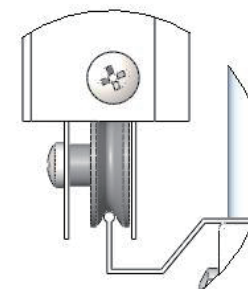

C

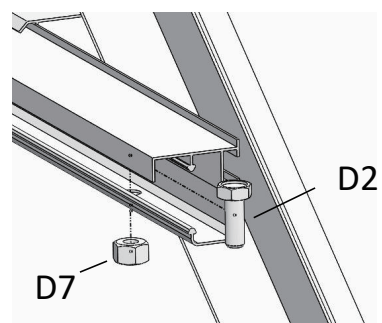

# Top Beam – Belka górna

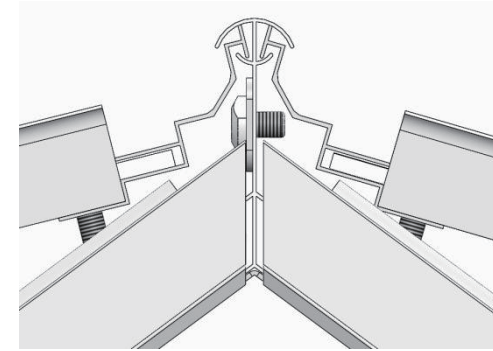
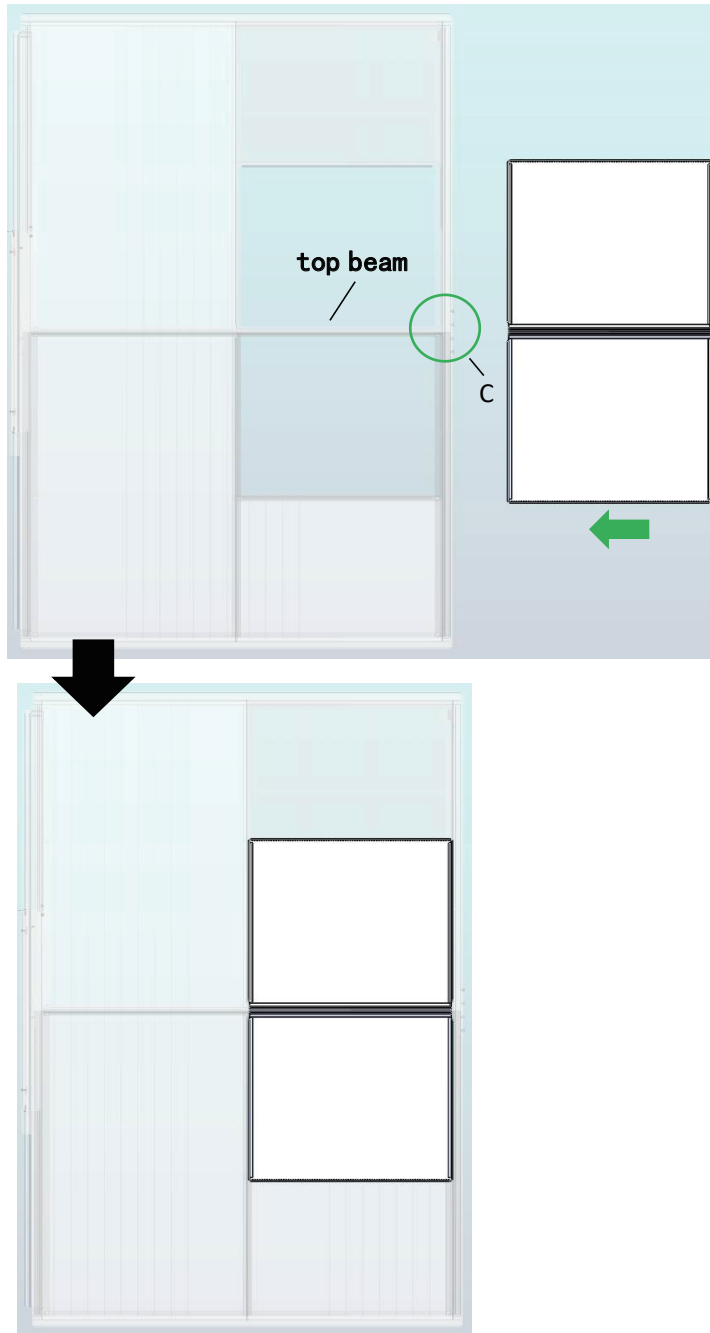

Ⓒ

# Tylna część

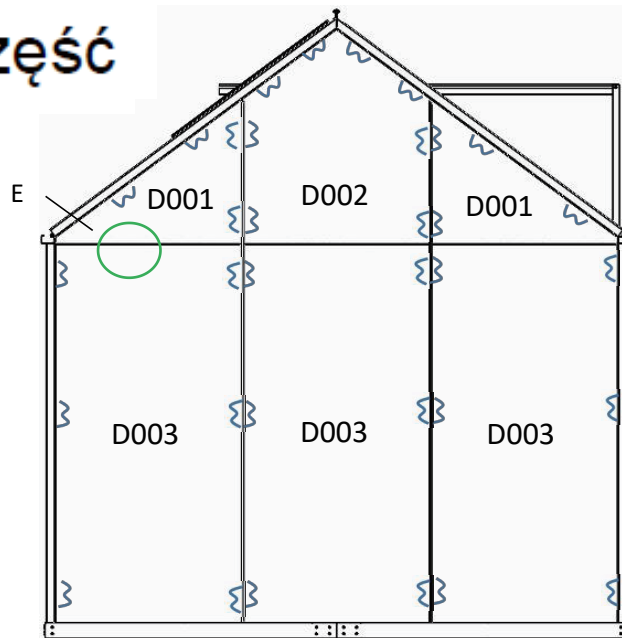
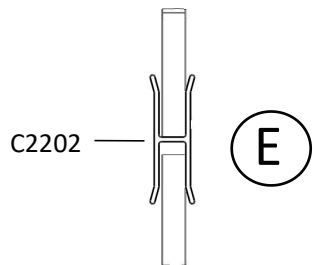

MODEL	CODE	LENGTH(mm)	QTY
	C2201	621	2
	C2202	610	3
	C4		120

MODEL - MODEL      CODE - KOD

LENGTH - DŁUGOŚĆ      QTY - ILOŚĆ

# Prawa strona

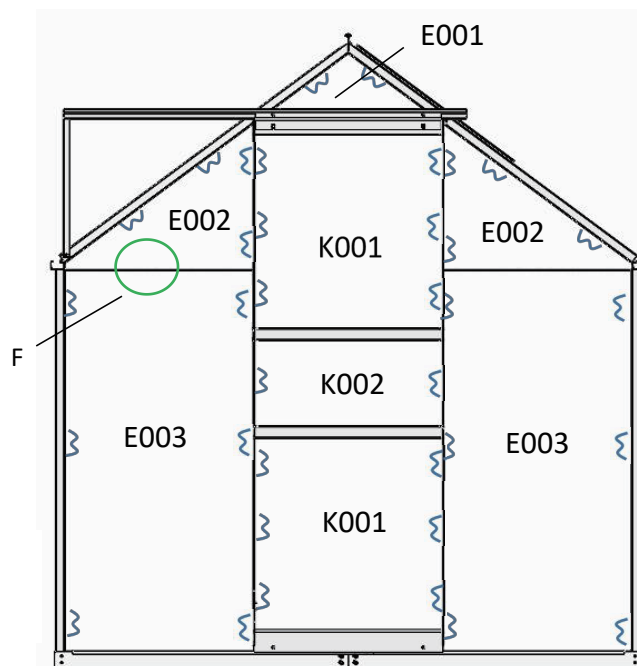
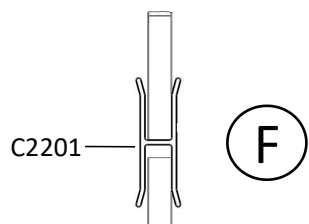

# Lewa strona

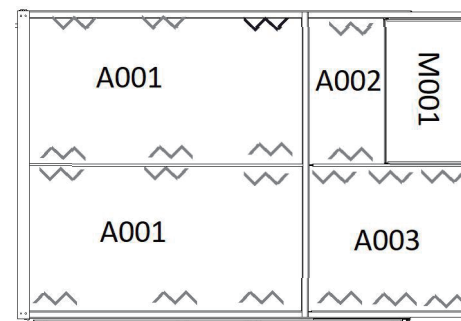

**Uwaga:** Pierwsza płyta jest wstawiona do części aluminiowej. Następnie trzeba umieścić sprężynę na zewnętrzną powierzchnię naprzeciwko płyty w kierunku instalacji pokazanym na poniższym rysunku.

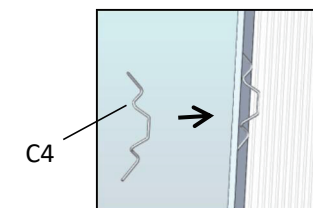

# Przednia część



## Po montażu

Szklarnię trzeba regularnie i dokładnie obserwować w celu sprawdzenia, czy są wszystkie części należycie przymocowane i cała konstrukcja jest poprawna. Należy skontrolować wszystkie śruby i nakrętki oraz wszystkie połączenia w celu sprawdzenia ich poprawnego położenia.

Bardzo polecamy zaraz usuwać spadły śnieg. Nie pozostawiać w ciągu nocy śniegu na dachu. Z wszystkich stron trzeba pozostawiać wolną przestrzeń o szerokości około 1 metra.

Śnieg nie powinien zalegać po stronach szklarni. W odwrotnym przypadku dochodzi do naporu w kierunku do środka, co może spowodować runięcie szklarni.